



# **BE-870LM vehicle CCTV monitor**

## **User & fitting guide**

**User Guide & montage**

**User & Einbau Anleitung**

**Utente di montaggio e guida**

**Guía de usuario y montaje**

**User & montage handleiding**



Stock code #3146



# 1 Contents/Contenu/Inhalt/Contenuti/Contenidos/inhoud

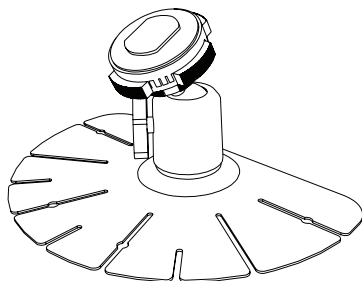
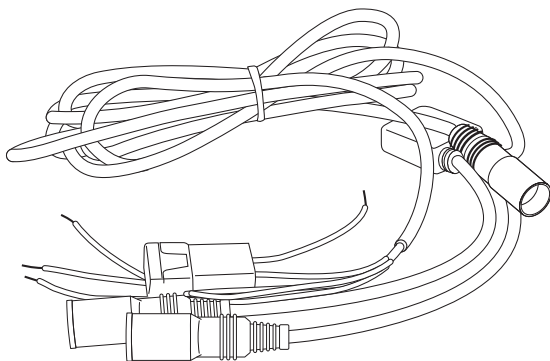
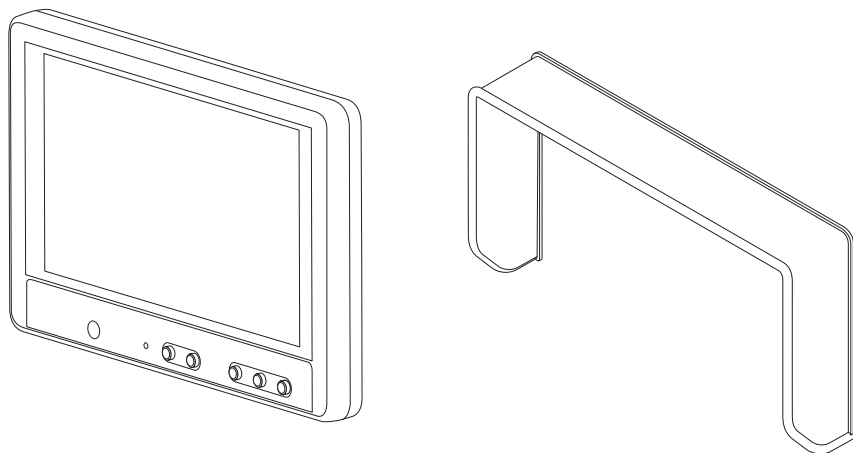

## 2 Monitor installation/Surveiller l'installation/ Monitor-Installation/L'installazione del monitor/ Vigilar la instalación/Monitor installatie

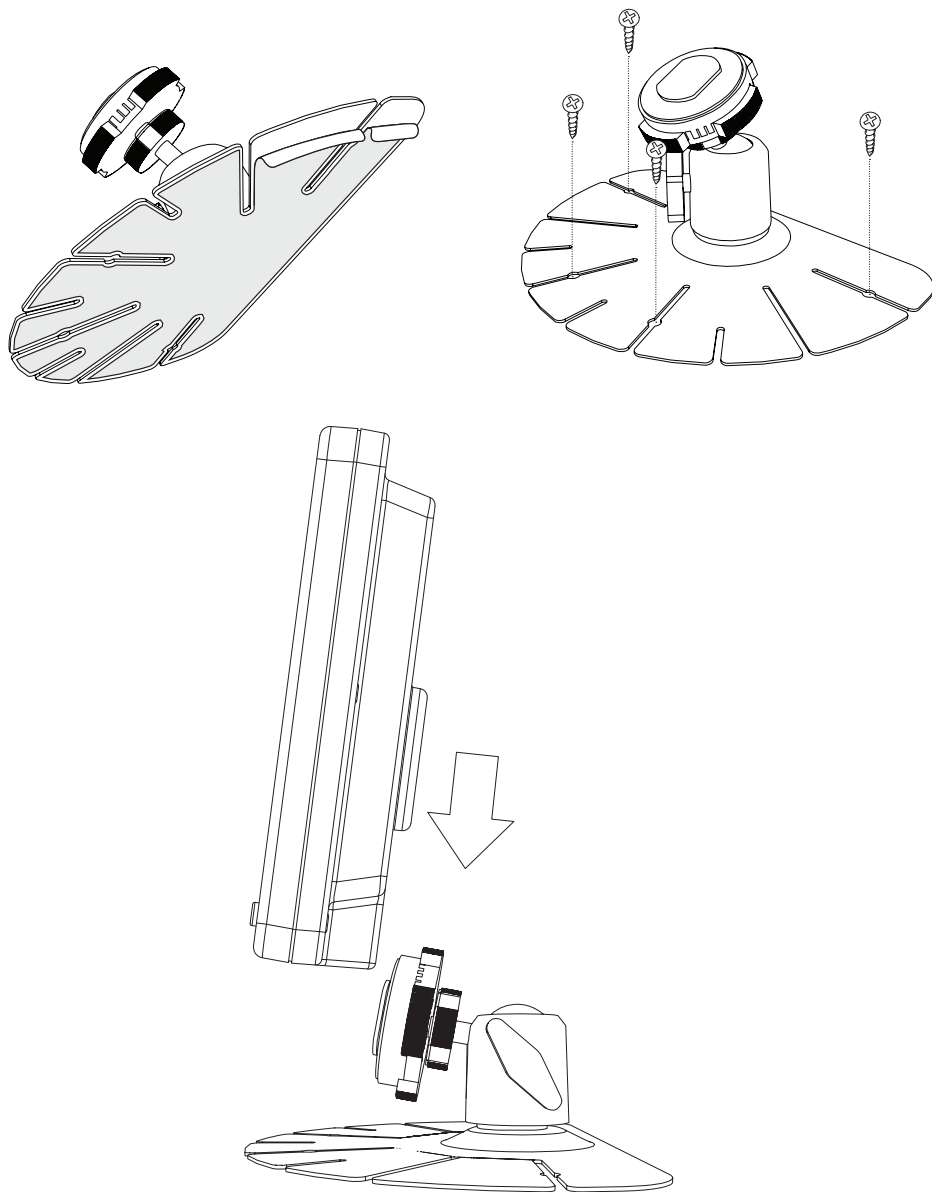

# 3 Connections/Connexions/Verbindungen/ Connessioni/Conexiones/Aansluitingen

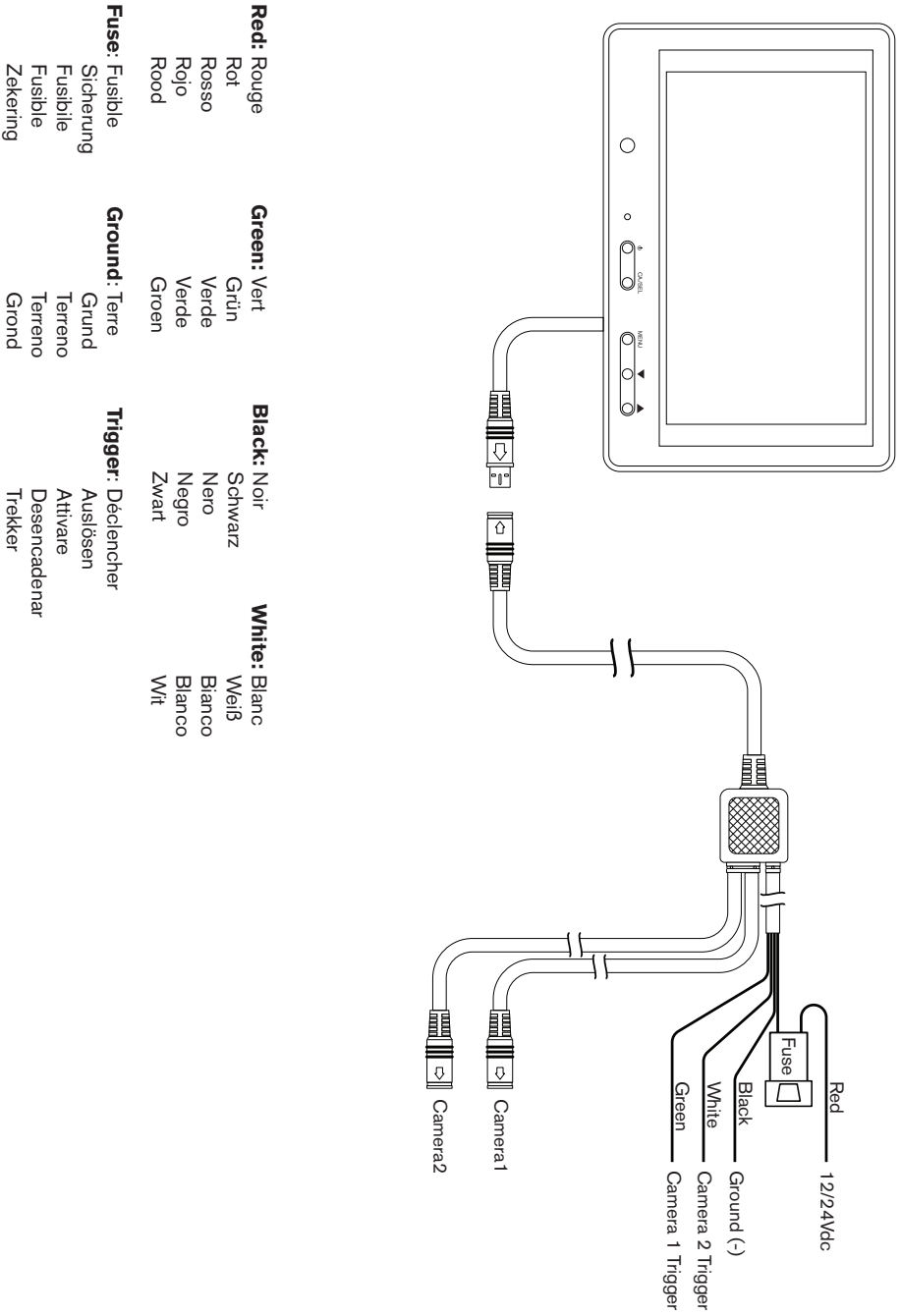

# 4 Controls/Contrôles/Kontrollen/Controlli/Controles/Controles/

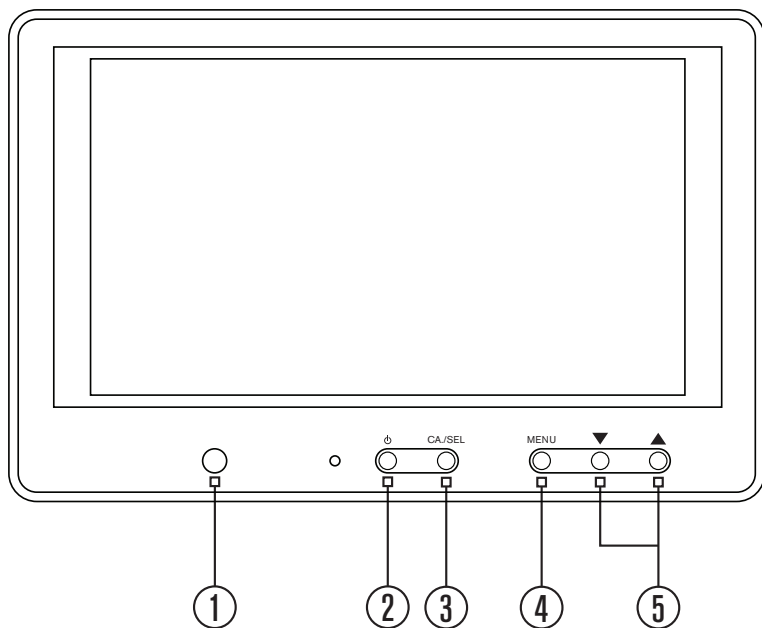

- ① Automatic low light sensor - automatically adjusts monitor brightness.  
Capteur optique automatique de basse luminosité - Réglage automatique de luminosité du moniteur  
Automatischer Low-Light Sensor - passt Monitorhelligkeit automatisch an  
Sensore automatico di bassa luminosità - varia automaticamente la luminosità dello schermo  
Sensor automático de baja luminosidad - adapta automáticamente la luminosidad del monitor  
Automatische low-light sensor - past de helderheid van de monitor automatisch aan

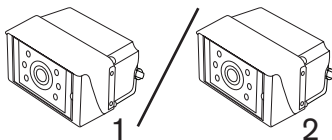

# 4 Controls/Contrôles/Kontrollen/Controlli/Controles/Controles

## ④ MENU

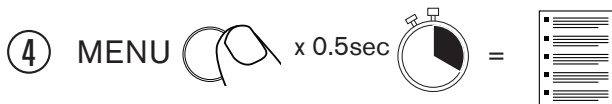

# 5 Operation/Opération/Betrieb/Operazione/Operación/ Werking

Auto Power ○/—



# 6 Set up menu/Menu setup/Setup Menü/Menu setup/Menü setup/Setup menu

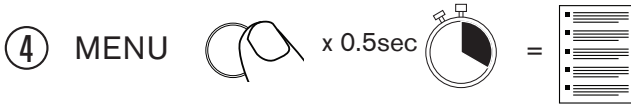

- 1. NORMAL / MIRROR
- 2. TRIGGER DELAY
- 3. CAMERA NAME
- 4. SCALE MODE
- 5. **ADVANCED MENU**
- 6. AUTO SCAN

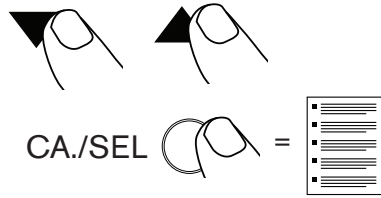

- 1. DISPLAY: [FULL;NORMAL]
- 2. UP/DOWN
- 3. DAY/NIGHT
- 4. AUTO POWER: [OFF;ON]
- 5. **LANGUAGE: [ENGLISH;DEUTCH;  
FRANCAIS;ITALIANO;ESPANOL]**

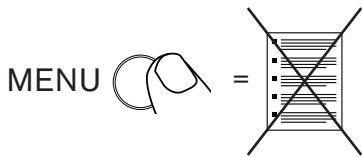

# 7 Specifications/Specifications/ Spezifikationen/ Specifiche/Especificaciones/Specificaties

## ENGLISH

Specifications	
Monitor	BE-870LM
TV system	NTSC/PAL
Picture	7" TFT LCD colour monitor with on-screen display function
Display size	7" diagonal
Field of view	Top: 30°, Bottom: 60°, Left: 60°, Right: 60°
Resolution	(480x3(RGB)x234)
Picture image	Factory set to reverse image
Power	10~32Vdc input
Inputs	2 x camera
Dimensions	197(w) x 128(h) x 29(d)mm 7.8(w) x 4.9(h) x 1.2(d) inches
Operating temperature	-40°C ~ +70°C -40°F ~ +158°F

## FRANCAIS

Specifications	
Moniteur	BE-870LM
Système TV	NTSC/PAL
Image	7" TFT LCD moniteur couleur avec affichage de fonction (OSD)
Dimension de l'écran	7" diagonal
Champ de vision	Haut: 30°, Bas: 60°, Gauche: 60°, Droite: 60°
Résolution	(480x3(RGB)x234)
Image vidéo	Réglage d'usine sur image inverse
Alimentation	10~32Vdc input
Entrées	2 x caméra
Dimensions	197(w) x 128(h) x 29(d)mm 7,8(w) x 4,9(h) x 1,2(d) inches
Température d'utilisation	-40°C ~ +70°C -40°F ~ +158°F

## ITALIANO

Specifiche	
Schermo	BE-870LM
Sistema TV	NTSC/PAL
Immagine	7" TFT LCD colour monitor with on-screen display function
Formato display	7" diagonale
Campo visivo	Top: 30°, Bottom: 60°, Left: 60°, Right: 60°
Risoluzione	(480x3(RGB)x234)
Immagine a video	Immagine reversibile program- mabile
Alimentazione	10~32Vdc input
Prese	2 x telecamera
Dimensioni	197(w) x 128(h) x 29(d)mm 7.8(w) x 4.9(h) x 1.2(d) inches
Temperatura di servizio	-40°C ~ +70°C -40°F ~ +158°F

## DEUTSCH

Spezifikationen	
Monitor	BE-870LM
TV-System	NTSC/PAL
Bild	7" TFT LCD Farbmonitor mit Funktionsanzeige (OSD)
Bildschirmgröße	7" diagonal
Sichtfeld	Oben: 30°, Unten: 60°, Links: 60°, Rechts: 60°
Auflösung	(480x3(RGB)x234)
Videobild	Werkseinstellung Reversebild
Stromversorgung	10~32Vdc input
Eingänge	2 x kamera
Abmessungen	197(w) x 128(h) x 29(d)mm 7.8(w) x 4.9(h) x 1.2(d) inches
Betriebstemperatur	-40°C ~ +70°C -40°F ~ +158°F

# 7 Specifications/Spécifications/Spesifikationen/ Specifiche/Especificaciones/Specificaties

ESPAÑOL	
<b>Especificaciones</b>	
Monitor	BE-870LM
Sistema de TV	NTSC/PAL
Imagen	Monitor a color de 7" TFT LCD con visualización de las funciones (OSD)
Tamaño de pantalla	7" diagonal
Campo visual	arriba: 30°, abajo: 60°, a la izquierda: 60°, a la derecha: 60°
Resolución	(480x3(RGB)x234)
Imagen de video	Ajuste de fábrica de la imagen inversa
Suministro de corriente	10~32Vdc entrada
Entradas	2 x cámara
Dimensiones	197(w) x 128(h) x 29(d)mm 7.8(w) x 4.9(h) x 1.2(d) inches
Temperatura de servicio	-40°C ~ +70°C -40°F ~ +158°F

NEDERLANDS	
<b>Specificaties</b>	
Monitor	BE-870LM
TV-systeem	NTSC/PAL
Beeld	7" TFT LCD colour monitor with on-screen display function
Displayformaat	7" diagonaal
Gezichtsveld	Boven: 30°, Onder: 60°, Links: 60°, Rechts: 60°
Resolutie	(480x3(RGB)x234)
Videobeeld	Fabriekinstelling reversebeeld
Stroomvoorziening	10~32Vdc Ingang
Ingangen	2 x camera
Afmetingen	197(w) x 128(h) x 29(d)mm 7.8(w) x 4.9(h) x 1.2(d) inches
Bedrijfstemperatuur	-40°C ~ +70°C -40°F ~ +158°F

Specifications subject to change. Sous réserve de modifications techniques. Vorbehaltlich technischer Änderungen. Con riserva di modifichite tecniche. Reservadas las modificaciones técnicas. Technische wijzigingen voorbehouden.

## **Disclaimer**

Camera monitor systems are an invaluable driver aid but do not exempt the driver from taking every normal precaution when conducting a manoeuvre. No liability arising out of the use or failure of the product can in any way be attached to Brigade or to the distributor.

## **Dénégation**

Les systèmes de moniteurs des caméras sont une aide précieuse pour le conducteur, mais celui-ci doit toutefois prendre toutes les précautions nécessaires pendant les manœuvres. Brigade ou ses distributeurs n'assument aucune responsabilité résultant de l'utilisation ou d'un défaut du produit.

## **Verzichterklärung**

Die Kamerabildschirmssysteme sind eine wertvolle Hilfe für den Fahrer, entbinden ihn jedoch nicht von der notwendigen Sorgfalt beim Manövrieren des Fahrzeuges. Brigade und seine Vertriebshändler haften nicht für Schäden aus der Nutzung oder einer Fehlfunktion des Produktes.

## **Disconoscimento**

I sistemi di monitor della telecamera sono un aiuto prezioso per il conduttore, ma non lo esonerano dall'obbligo di prendere le precauzioni necessarie durante le manovre del veicolo. Brigade e i suoi distributori non si assumono nessuna responsabilità per danni risultanti dall'utilizzo o da un malfunzionamento del prodotto.

## **Negante**

Los sistemas de pantalla de cámara son una valiosa ayuda destinada a los conductores; en todo caso no les resta la responsabilidad de proceder con precaución a la hora de maniobrar con el vehículo. Brigade y sus distribuidores comerciales no se responsabilizan de los daños derivados de un mal funcionamiento del producto.

## **Verweping**

De camera-monitorsystemen zijn een waardevolle hulp voor de bestuurder, ontheffen hem echter niet van de nodige zorgvuldigheid bij het manoeuvreren van het voertuig. Brigade en zijn distributeurs zijn niet aansprakelijk voor schade door gebruik of een gebrek van het product.

Serial No:

Stock code:



#### **Head Office**

Brigade Electronics plc  
Brigade House, The Mills  
Station Road, South Darent  
DA4 9BD United Kingdom  
Tel: +44 (0)1322 420300  
Fax: +44 (0)1322 420343  
email: sales@brigade-electronics.com

Brigade Electronics Inc  
202 Delaware Avenue, Suite 1  
Palmerton PA 18071 USA  
Tel: +1 (610) 826-7870  
Fax: +1 (484) 229-0088  
email: infousa@brigade-electronics.com

Brigade Electronique Sarl  
22 Rue Pierre Bontemps  
72000 Le Mans  
France  
Tel: +33 (0) 2 23 61 08 97  
Fax +33 (0) 2 23 61 08 97  
email: info@brigade-electronique.fr

Brigade Elettronica srl  
Via V. Alfieri n. 28  
50121 - Firenze  
Italia  
Telefono: +39 (0) 55 24 59 43  
email: info-italia@brigade-electronics.com

Brigade Elektronik GmbH  
Haberstr. 36 A  
24537 Neumünster Germany  
Telefon: +49 (0) 4321 555 362  
Fax: +49 (0) 4321 555 361  
email: info@brigadegmbh.de

